

## DXD-6B

## 工作条件 Working Conditions

输送介质:干燥空气

环境温度:≤50°C

最大工作压力:0.1Mpa

Conveying Medium: Dry Air

Environmental Temperature:≤50°C

Max. Working Pressure: 0.1Mpa

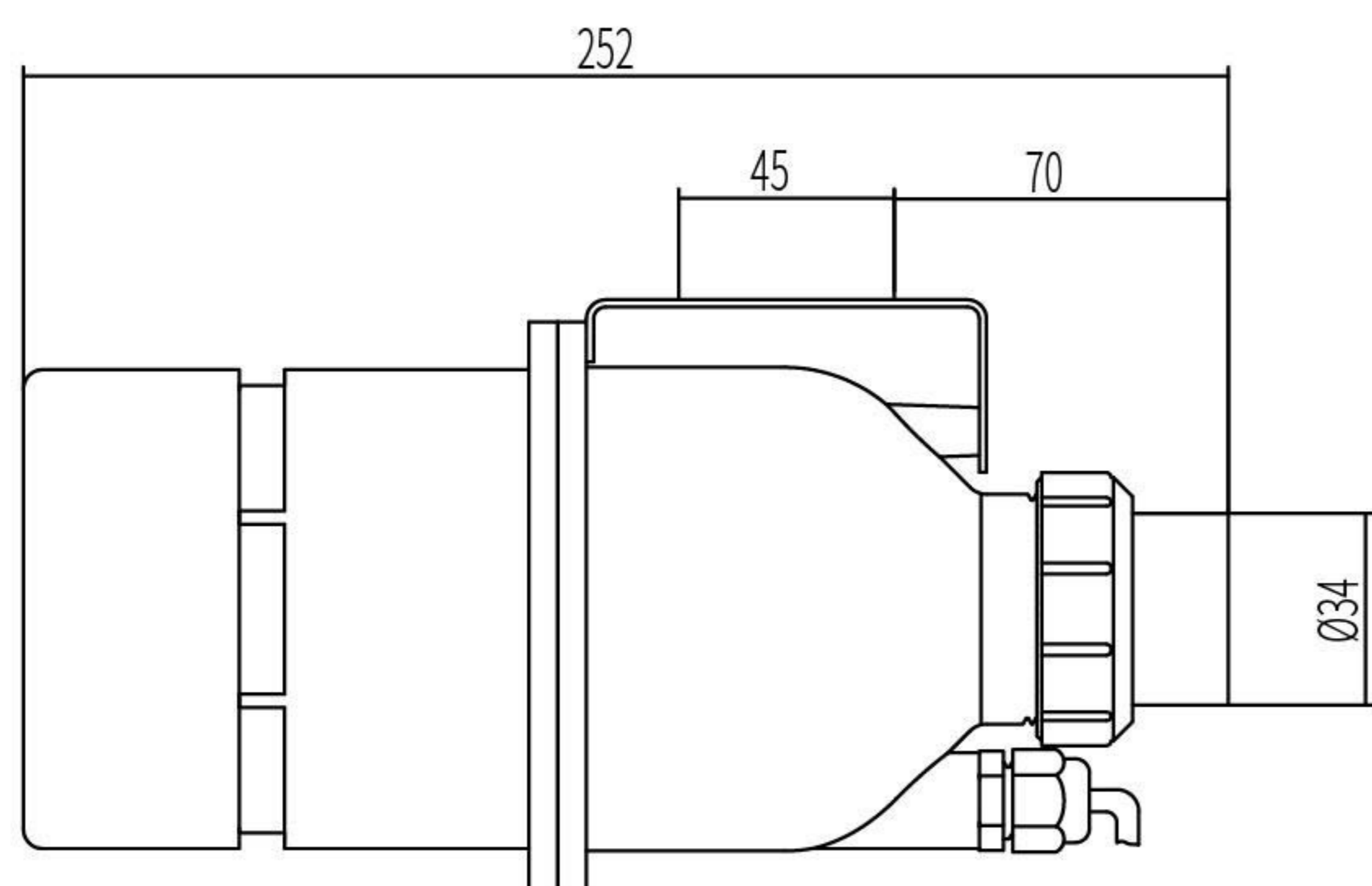
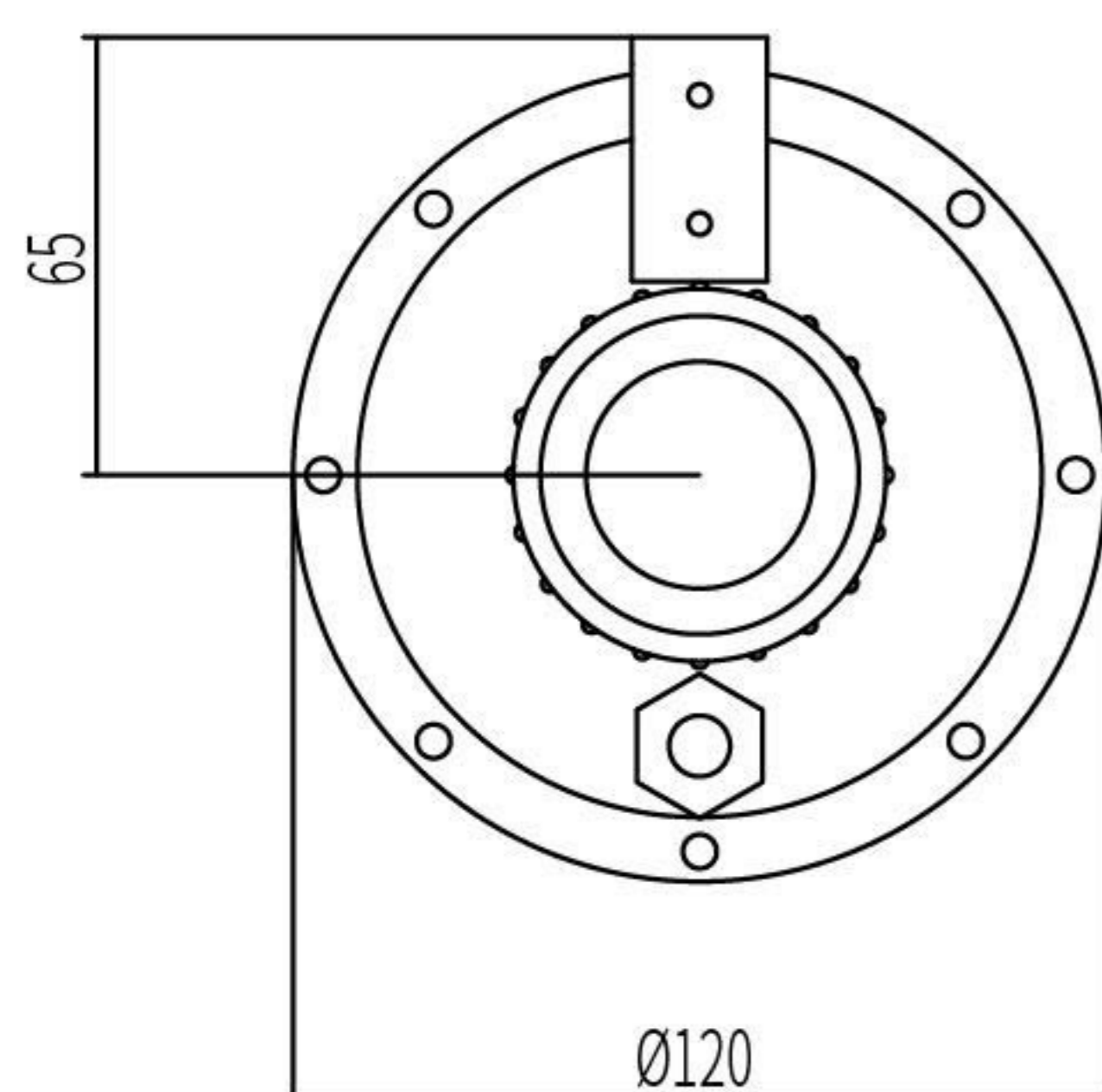

IEC 60335-1:2010  
IEC 60335-1:2010/AMD1:2013  
IEC 60335-1:2010/AMD2:2016  
IEC 60335-2-60:2017



AS/NZS 60335.2.60:2018  
AS/NZS 60335.1:2011 Inc A1-5



E351971



EN 60335-1:2012/A2:2019  
EN 60335-2-60:2003/A12:2010



EN 60335-1:2012/A2:2019  
EN 60335-2-60:2003/A2:2010

## 技术参数 Technical Parameter List

型号 Model	电压 Voltage	功率 Power		转速 Rotating Speed (r/min)	风速 Wind Speed (Km/h)	噪音 Noise(dB)	绝缘等级 Insulation Class	防护等级 Protection Grade	毛重 Gross Weight (kg)	认证 Certification
		Kw	HP							
DXD-6B-200	230v/50Hz/60Hz	0.20	0.25	20000	55	66	F	IP X5	2.0	
DXD-6B-350	230v/50Hz/60Hz	0.35	0.5	23000	65	73	F	IP X5	2.0	
DXD-6B-200	115v/50Hz/60Hz	0.20	0.25	20000	55	66	F	IP X5	2.0	
DXD-6B-350	115v/50Hz/60Hz	0.35	0.5	23000	65	73	F	IP X5	2.0	

包装 (Packing): 310mm×170mm×185mm