

DXD-315A

工作条件 Working Conditions

介质温度:5-50°C

环境温度:≤50°C

湿度:65%RH

最大工作压力:0.4Mpa

Medium temperature:5-50°C

Environmental temperature:≤50°C

Humidity: 65% RH

Max.working pressure: 0.4Mpa

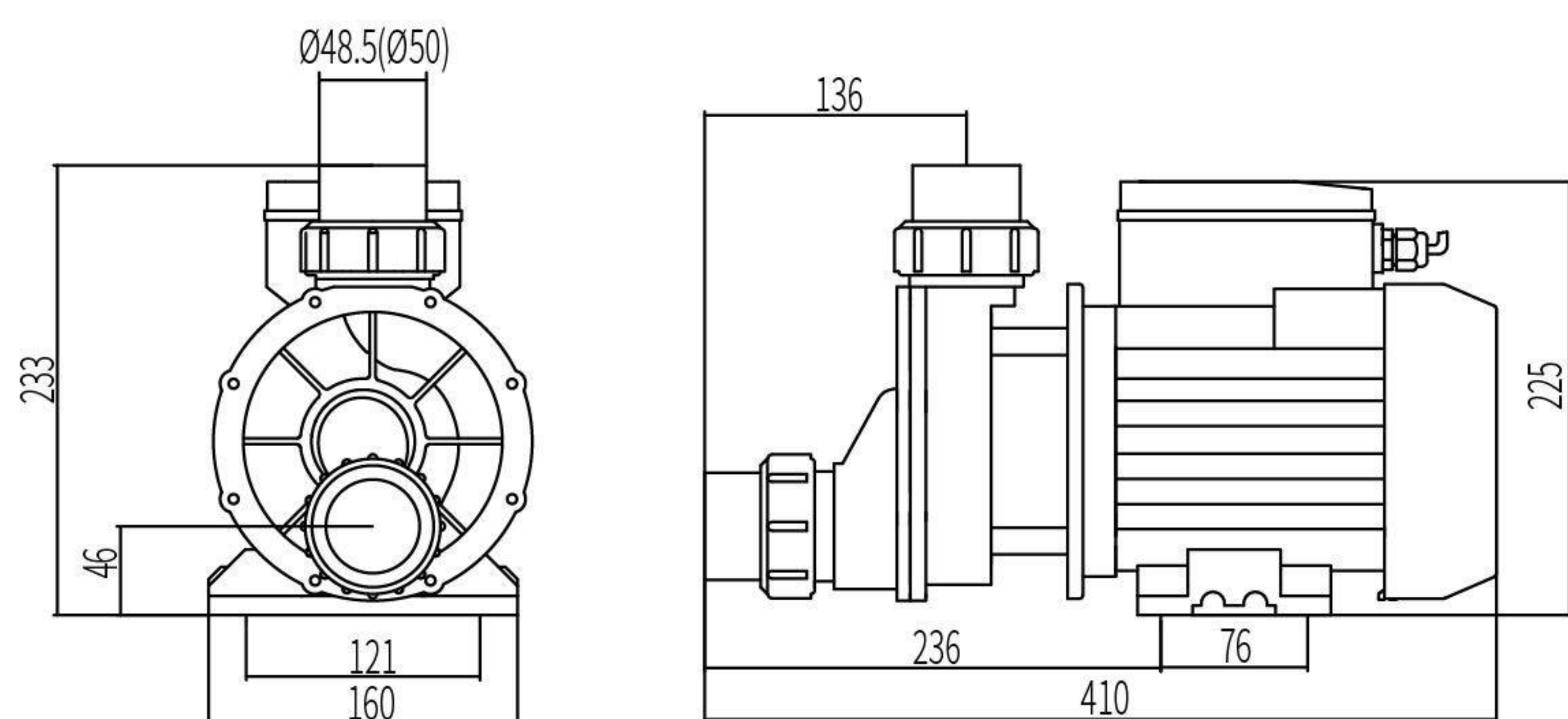

性能曲线 Performance Curves

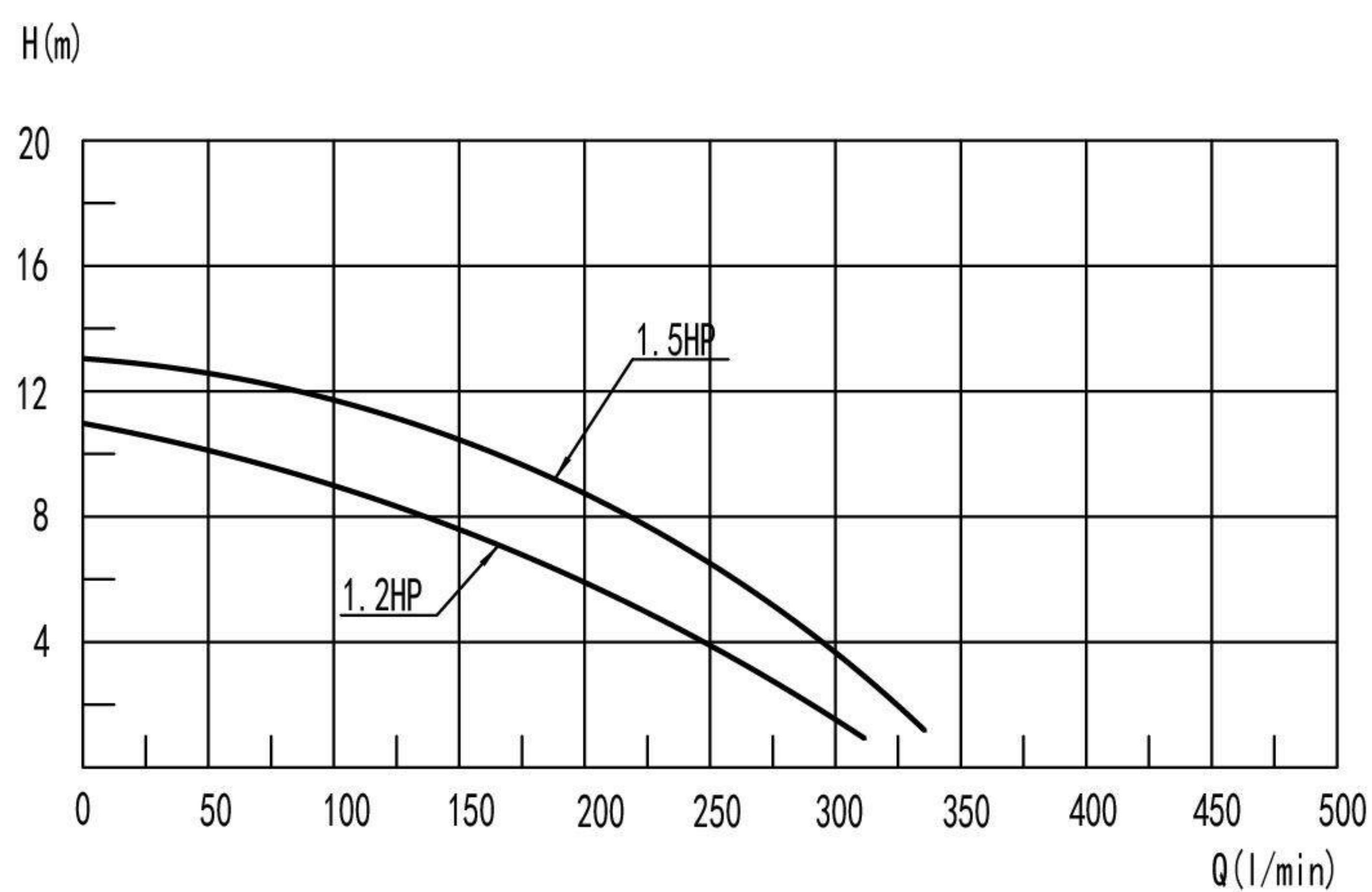

E351970

EN 60335-1:2012/A2:2019
 EN 60335-2-41:2003/A2:2010
 EN 62233:2008

EN 60335-1:2012/A2:2019
 EN 60335-2-41:2003/A2:2010
 EN 62233:2008

技术参数 Technical Parameter List

型号 Model	电压 Voltage	功率 Power		转速 Rotating Speed (r/min)	最大扬程 Maximum Lift (m)	最大流量 Maximum Flow (l/min)	绝缘等级 Insulation Class	防护等级 Protection Grade	毛重 Gross Weight (kg)	认证 Certification
		Kw	HP							
DXD-315A	230v/50Hz	1.1	1.5	2850	13.0	333	F	IP X5	10.5	
DXD-315C	230v/60Hz	1.1	1.5	3450	13.0	333	F	IP X5	10.5	
DXD-315D-900	115v/60Hz	0.9	1.2	3450	11.0	317	F	IP X5	10.5	
DXD-315D-1100	115v/60Hz	1.1	1.5	3450	13.0	333	F	IP X5	10.5	

包装 (Packing): 400mm×170mm×250mm

可选配定时功能和无水保护装置 Optional function: Timer&No Water Protection