

## DXD-310T

## 工作条件 Working Conditions

介质温度: 5-50°C

环境温度: ≤50°C

湿度: 65% RH

最大工作压力: 0.4Mpa

Medium temperature: 5-50°C

Environmental temperature: ≤50°C

Humidity: 65% RH

Max.working pressure: 0.4Mpa

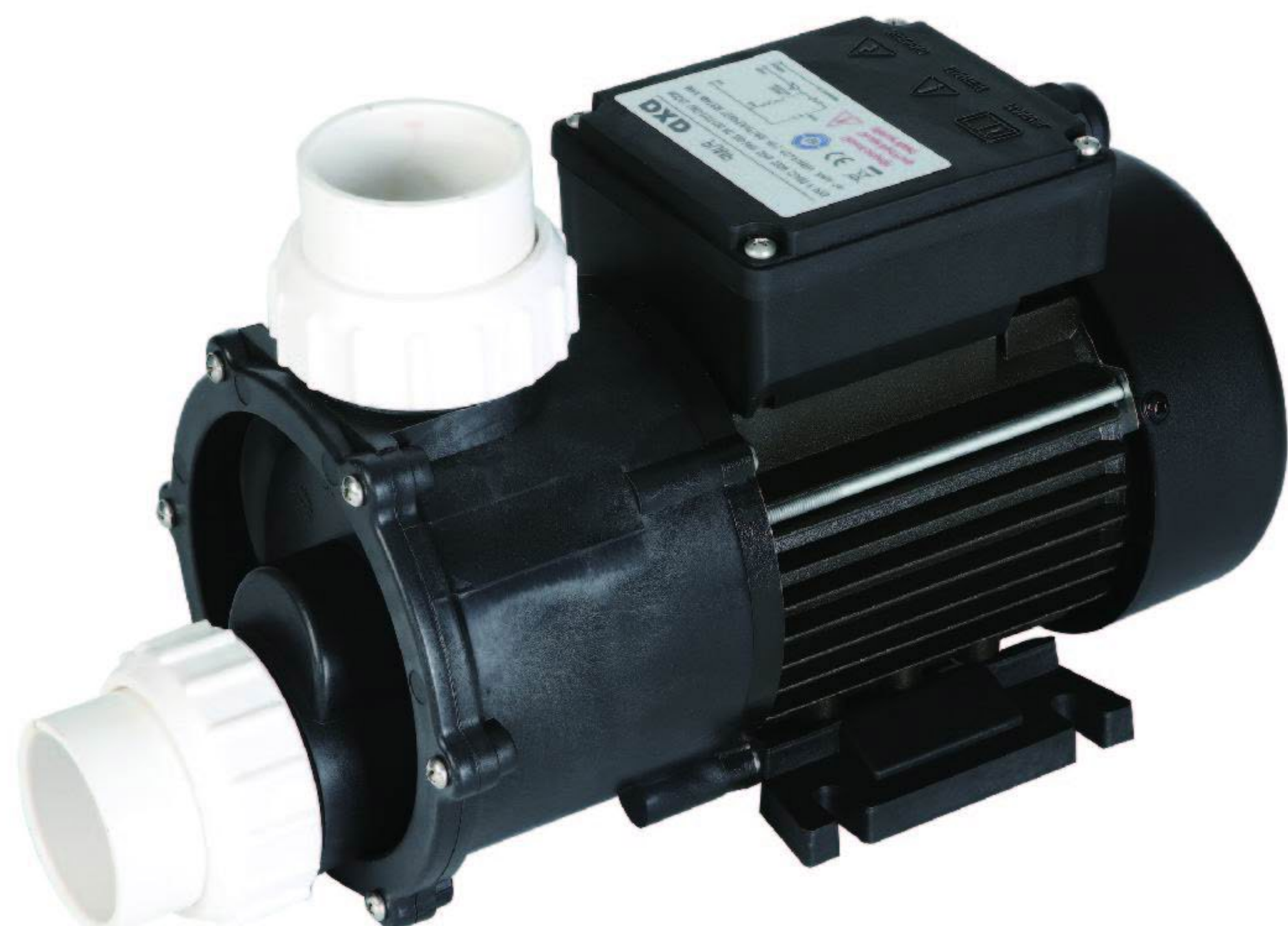
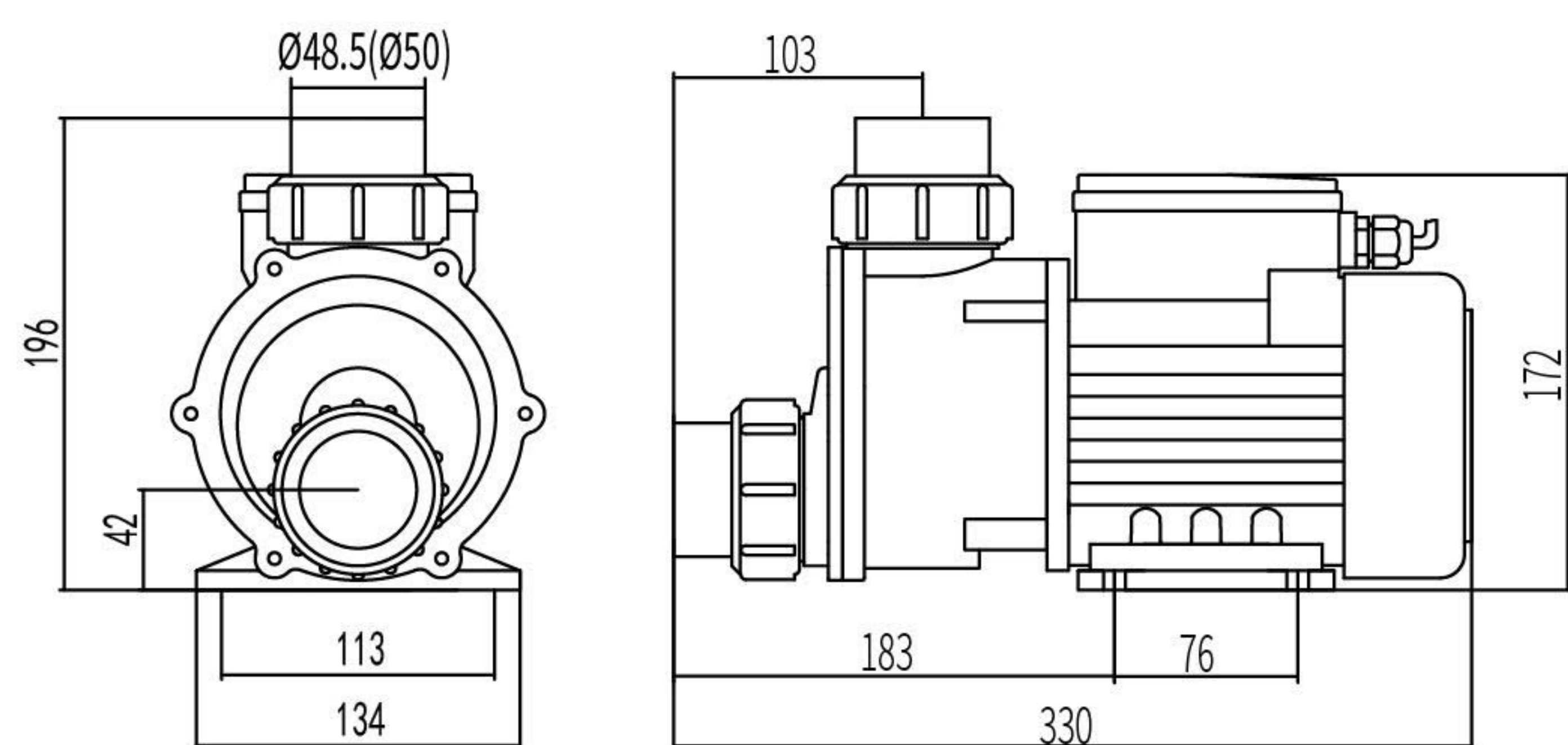

## 性能曲线 Performance Curves

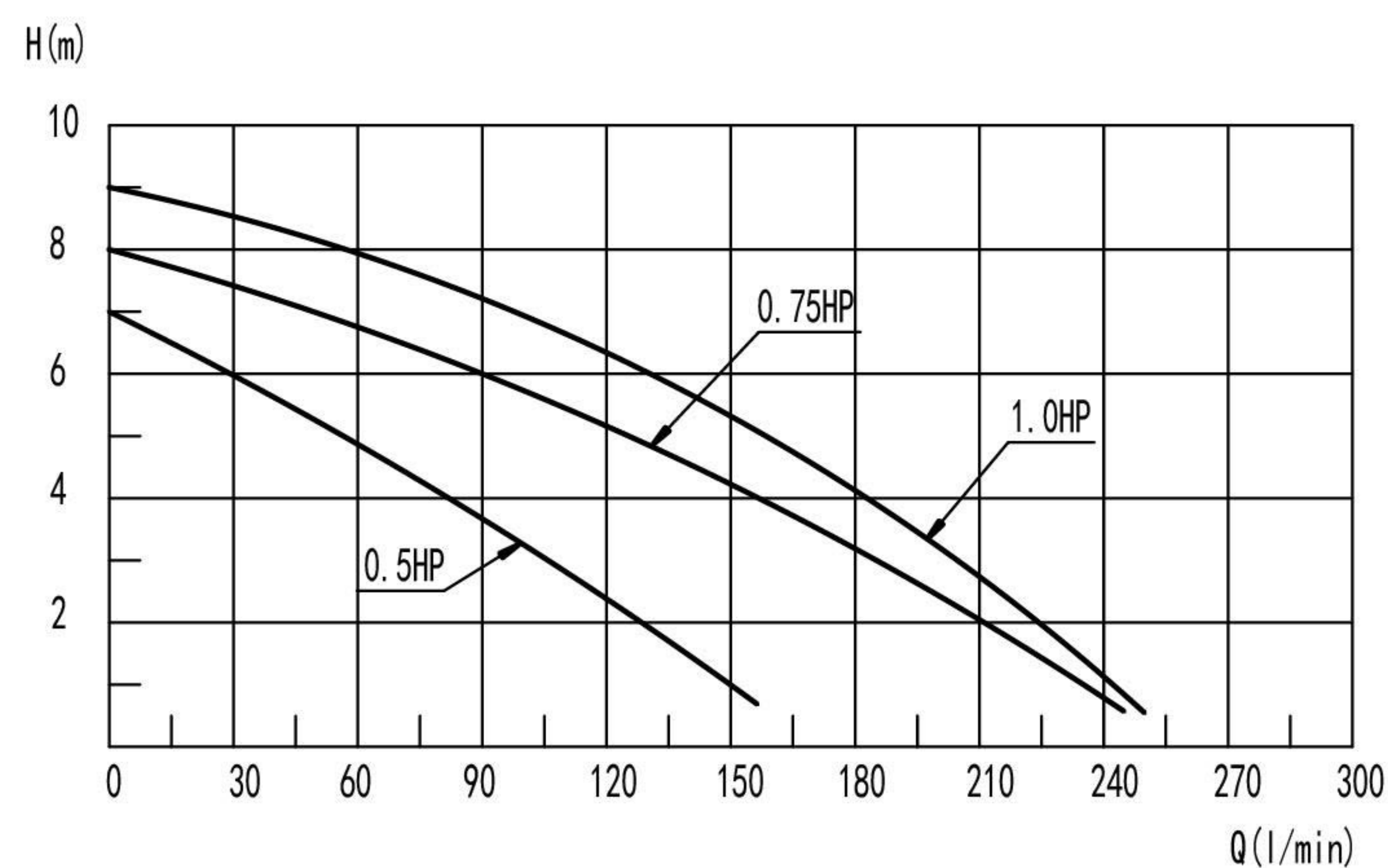

TUV  
EN 60335-1:2012/A2:2019  
EN 60335-2-41:2003/A2:2010  
EN 62233:2008

CE  
EN 60335-1:2012/A2:2019  
EN 60335-2-41:2003/A2:2010  
EN 62233:2008

cULus E351970

## 技术参数 Technical Parameter List

型号 Model	电压 Voltage	功率 Power		转速 Rotating Speed (r/min)	最大扬程 Maximum Lift (m)	最大流量 Maximum Flow (l/min)	绝缘等级 Insulation Class	防护等级 Protection Grade	毛重 Gross Weight (kg)	认证 Certification
		Kw	HP							
DXD-310T-350	230v/50Hz	0.35	0.5	2850	7.0	167	F	IP X5	4.5	TUV CE
DXD-310T	230v/60Hz	0.35	0.5	3450	7.0	167	F	IP X5	4.5	
DXD-310T	115v/60Hz	0.35	0.5	3450	7.0	167	F	IP X5	4.5	
DXD-310T	230v/50Hz	0.55	0.75	2850	8.0	250	F	IP X5	5.5	
DXD-310T	230v/60Hz	0.55	0.75	3450	8.0	250	F	IP X5	5.5	
DXD-310T	115v/60Hz	0.55	0.75	3450	8.0	250	F	IP X5	5.5	
DXD-310T-750	230v/50Hz	0.75	1.0	2850	9.0	261	F	IP X5	5.5	TUV CE
DXD-310T	230v/60Hz	0.75	1.0	3450	9.0	261	F	IP X5	5.5	
DXD-310T-750	115v/60Hz	0.75	1.0	3450	9.0	261	F	IP X5	5.5	cULus

包装 (Packing): 355mm × 160mm × 230mm

可选配定时功能和无水保护装置 Optional function: Timer & No Water Protection