

# DXD-310E

## 工作条件 Working Conditions

介质温度:5-50°C

环境温度:≤50°C

湿度:65%RH

最大工作压力:0.4Mpa

Medium temperature:5-50°C

Environmental temperature:≤50°C

Humidity: 65% RH

Max.working pressure: 0.4Mpa

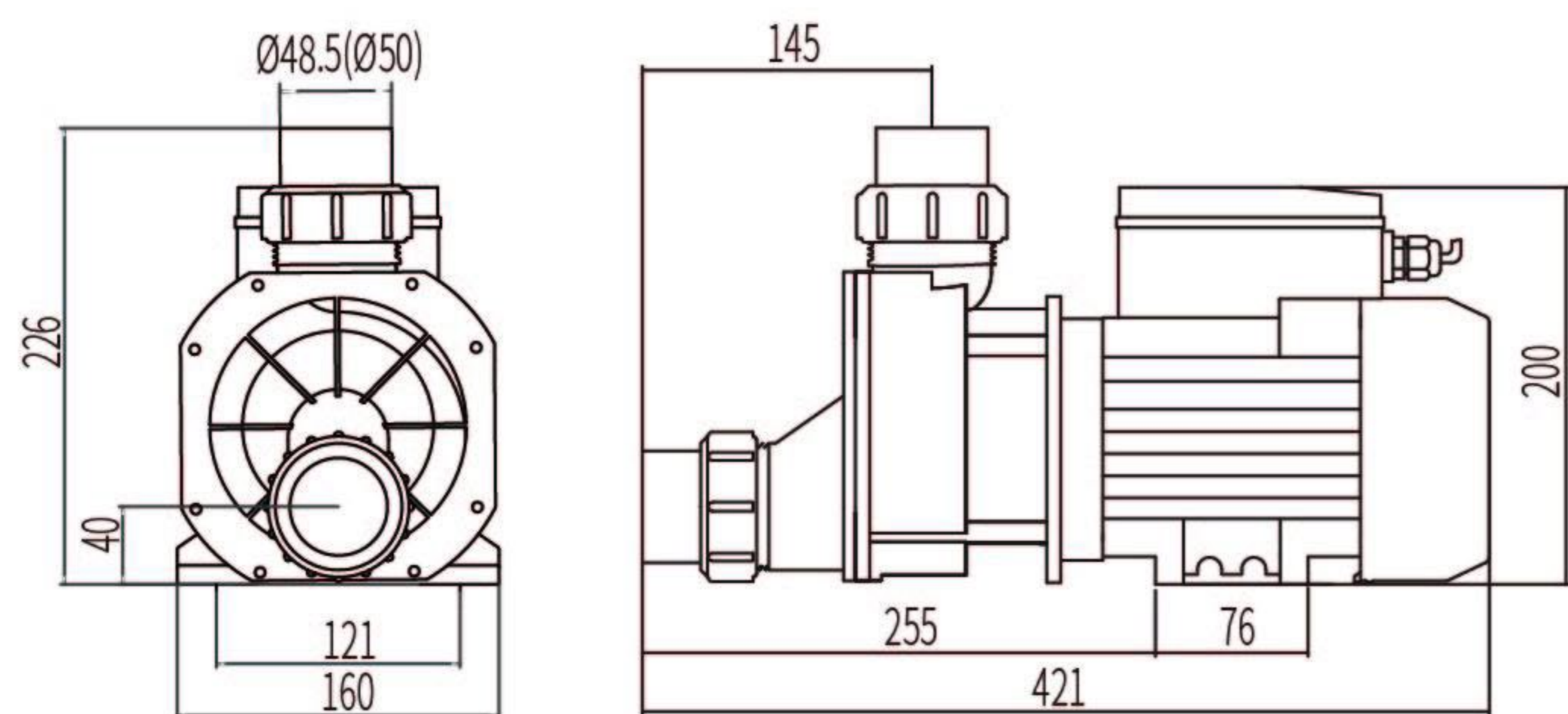

## 性能曲线 Performance Curves

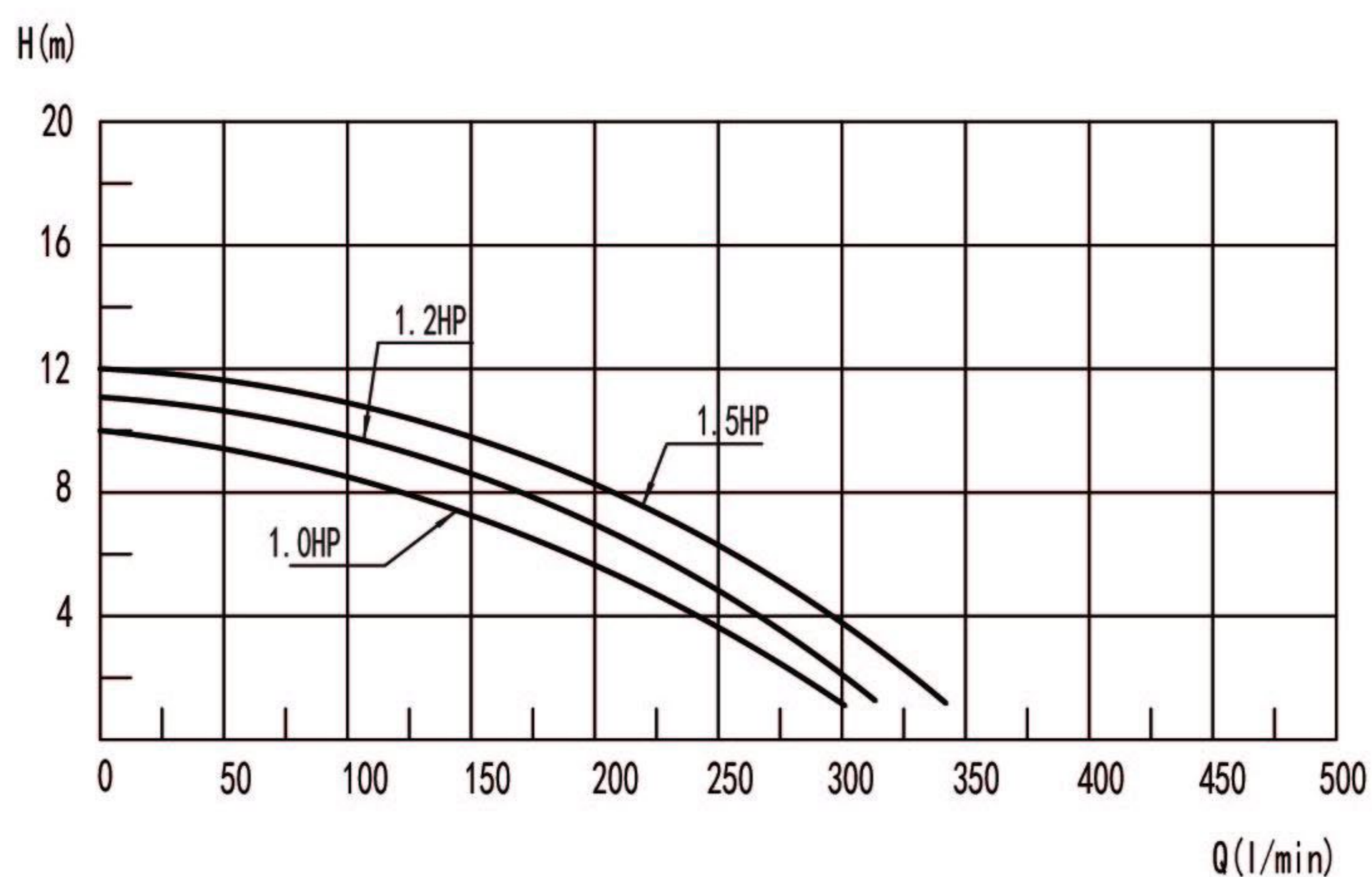

K60335-1, K60335-2-41, K00014-1

IEC60335-1:2010  
 IEC60335-1:2010/AMD1:2013  
 IEC60335-1:2010/AMD2:2016  
 IEC60335-2-41:2012

E351970

EN 60335-1:2012/A2:2019  
 EN 60335-2-41:2003/A2:2010  
 EN 62233:2008

EN 60335-1:2012/A2:2019  
 EN 60335-2-41:2003/A2:2010  
 EN 62233:2008

## 技术参数 Technical Parameter List

型号 Model	电压 Voltage	功率 Power		转速 Rotating Speed (r/min)	最大扬程 Maximum Lift (m)	最大流量 Maximum Flow (l/min)	绝缘等级 Insulation Class	防护等级 Protection Grade	毛重 Gross Weight (kg)	认证 Certification
		Kw	HP							
DXD-310E	230v/50Hz	0.75	1.0	2850	10.0	300	F	IP X5	8.0	
DXD-310F	230v/60Hz	0.75	1.0	3450	10.0	300	F	IP X5	8.0	
DXD-310G	115v/60Hz	0.75	1.0	3450	10.0	300	F	IP X5	8.0	
DXD-312E	230v/50Hz	0.9	1.2	2850	11.0	317	F	IP X5	9.2	
DXD-312F	230v/60Hz	0.9	1.2	3450	11.0	317	F	IP X5	9.2	
DXD-312G	115v/60Hz	0.9	1.2	3450	11.0	317	F	IP X5	9.2	
DXD-315E	230v/50Hz	1.1	1.5	2850	12.0	342	F	IP X5	9.6	
DXD-315F	230v/60Hz	1.1	1.5	3450	12.0	342	F	IP X5	9.6	
DXD-315G	115v/60Hz	1.1	1.5	3450	12.0	342	F	IP X5	9.6	

包装 (Packing): 405mm×170mm×215mm

可选配定时功能和无水保护装置 Optional function: Timer&No Water Protection