

DXD-310A

工作条件 Working Conditions

介质温度:5-50°C

环境温度:≤50 °C

湿度:65%RH

最大工作压力:0.4Mpa

Medium temperature : 5-50°C

Environmental temperature : ≤50°C

Humidity :65%RH

Max.working pressure : 0.4Mpa

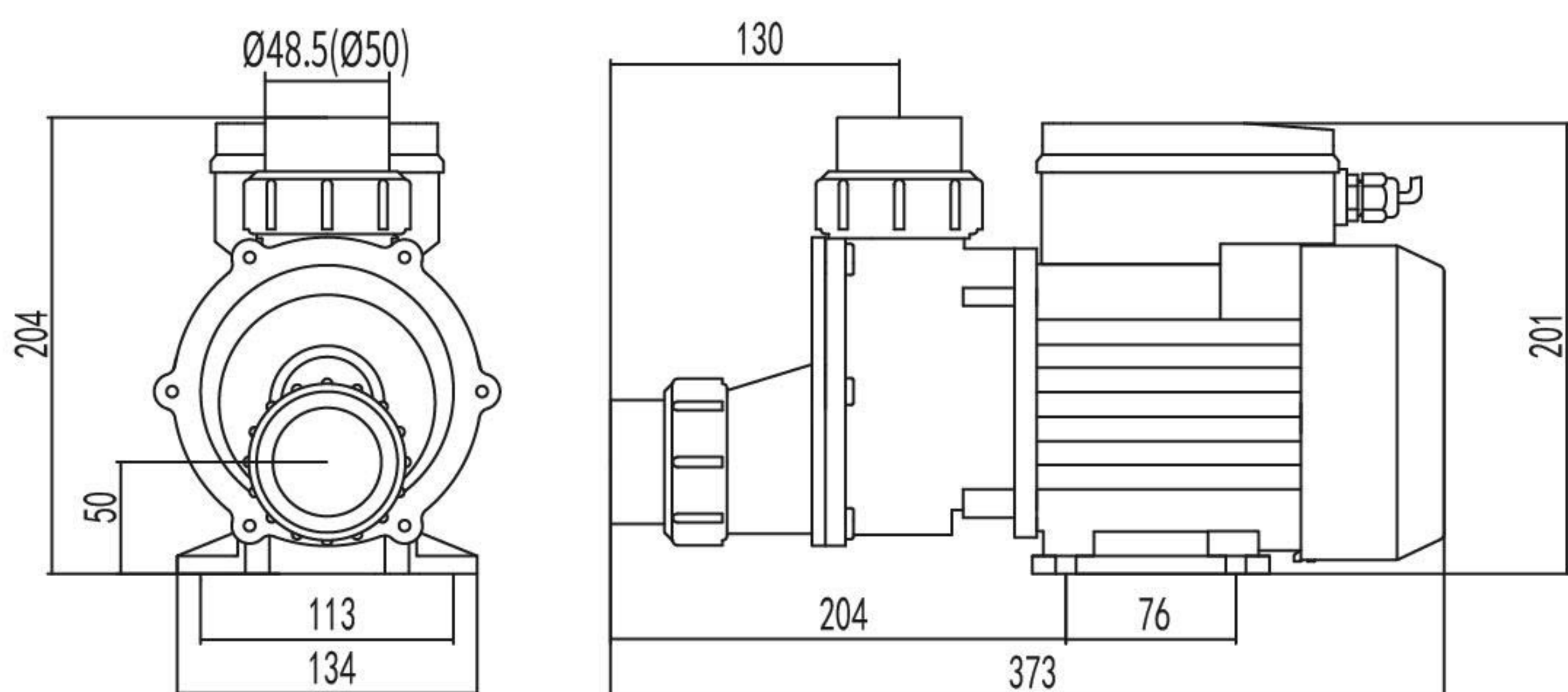

性能曲线 Performance Curves

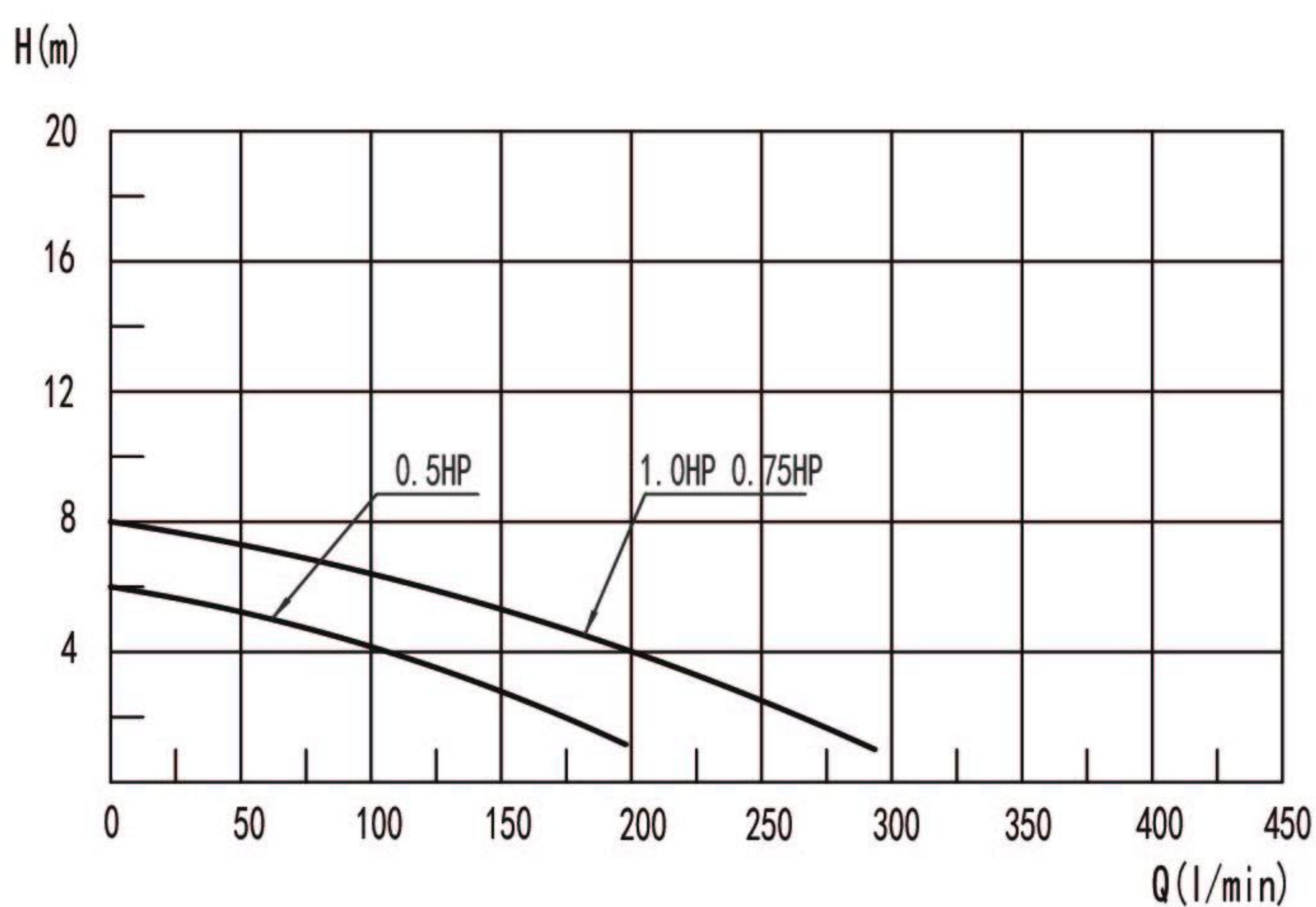

2196035

IEC60335-1:2010
IEC60335-1:2010/AMD1:2013
IEC60335-1:2010/AMD2:2016
IEC60335-2-41:2012

E351970

EN 60335-1:2012/A2:2019
EN 60335-2-41:2003/A2:2010
EN 62233:2008

AS/NZS 60335.2.41:2013 Inc A1
AS/NZS 60335.1:2011 Inc A1-5

EN 60335-1:2012/A2:2019
EN 60335-2-41:2003/A2:2010
EN 62233:2008

技术参数 Technical Parameter List

型号 Model	电压 Voltage	功率 Power		转速 Rotating Speed (r/min)	最大扬程 Maximum Lift (m)	最大流量 Maximum Flow (l/min)	绝缘等级 Insulation Class	防护等级 Protection Grade	毛重 Gross Weight (kg)	认证 Certification
		Kw	HP							
DXD-310A	230v/50Hz	0.75	1.0	2850	8.0	283	F	IP X5	6.8	
DXD-310C	230v/60Hz	0.75	1.0	3450	8.0	283	F	IP X5	6.8	
DXD-310D	115v/60Hz	0.75	1.0	3450	8.0	283	F	IP X5	6.8	
DXD-310B	230v/50Hz	0.55	0.75	2850	8.0	283	F	IP X5	6.5	
DXD-310X	230v/50Hz	0.4	0.5	2850	6.0	192	F	IP X5	6.0	
DXD-310Y	230v/60Hz	0.4	0.5	3450	6.0	192	F	IP X5	6.0	
DXD-310Z	115v/60Hz	0.4	0.5	3450	6.0	192	F	IP X5	6.0	

包装 (Packing): 355mm × 160mm × 230mm

可选配定时功能和无水保护装置 Optional function: Timer & No Water Protection