

## DXD-300E

## 工作条件 Working Conditions

介质温度: 5-50°C

环境温度: ≤50°C

湿度: 65% RH

最大工作压力: 0.4Mpa

Medium temperature: 5-50°C

Environmental temperature: ≤50°C

Humidity: 65% RH

Max.working pressure: 0.4Mpa

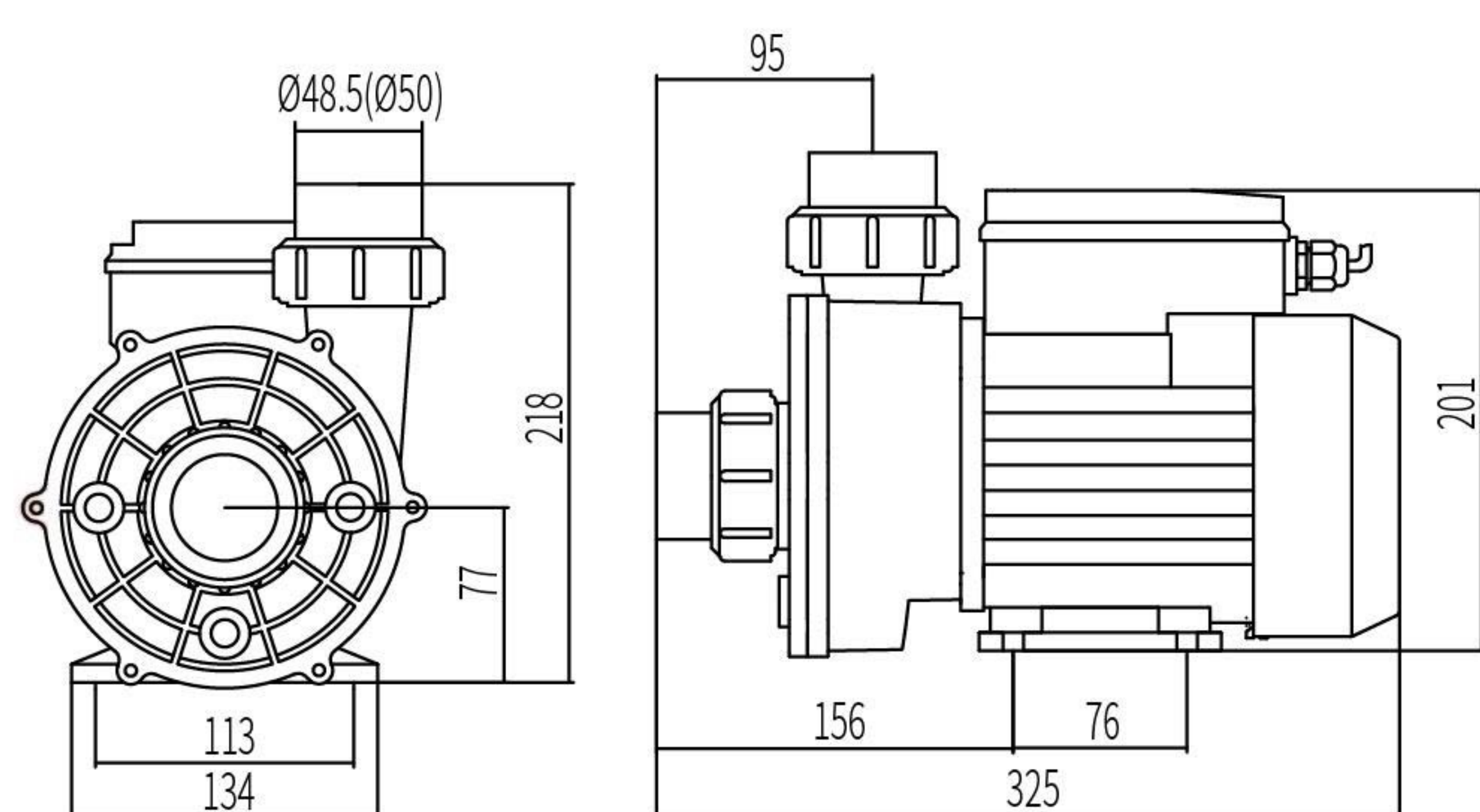

## 性能曲线 Performance Curves

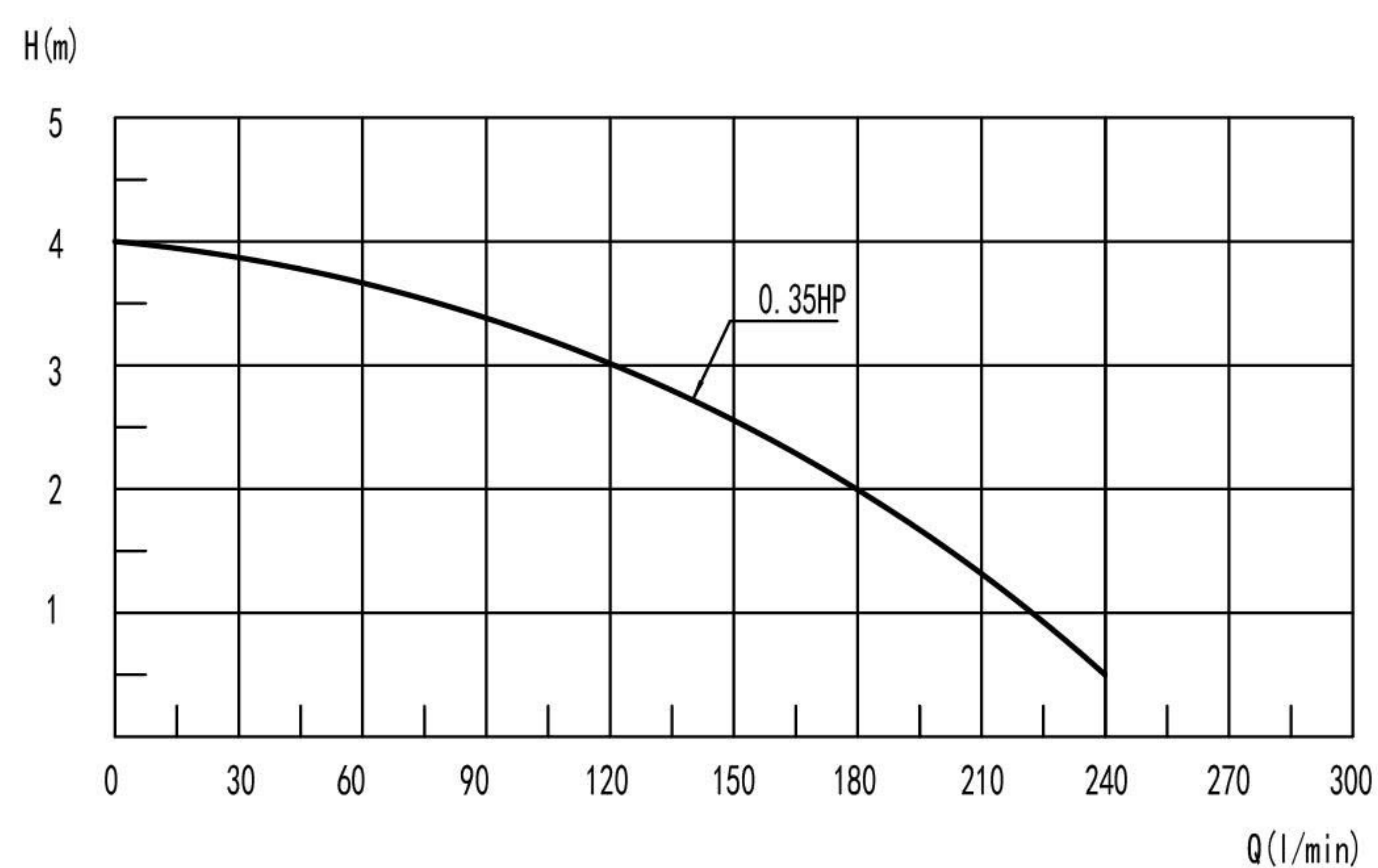

E351970



E351970



EN 60335-1:2012/A2:2019  
EN 60335-2-41:2003/A2:2010  
EN 62233:2008



IEC60335-1:2010  
IEC60335-1:2010/AMD1:2013  
IEC60335-1:2010/AMD2:2016  
IEC60335-2-41:2012



AS/NZS 60335.2.41:2013 Inc A1  
AS/NZS 60335.1:2011 Inc A1-5



EN 60335-1:2012/A2:2019  
EN 60335-2-41:2003/A2:2010  
EN 62233:2008

## 技术参数 Technical Parameter List

型号 Model	电压 Voltage	功率 Power		转速 Rotating Speed (r/min)	最大扬程 Maximum Lift (m)	最大流量 Maximum Flow (l/min)	绝缘等级 Insulation Class	防护等级 Protection Grade	毛重 Gross Weight (kg)	认证 Certification
		Kw	HP							
DXD-300E	230v/50Hz	0.25	0.35	1450	4.0	240	F	IPX5	6.0	
DXD-300E	230v/60Hz	0.25	0.35	1750	4.0	240	F	IPX5	6.0	
DXD-300E	115v/60Hz	0.25	0.35	1750	4.0	240	F	IPX5	6.0	

包装 (Packing): 310mm×185mm×230mm

可选配定时功能和无水保护装置 Optional function: Timer&No Water Protection