

## DXD-2A

## 工作条件 Working Conditions

介质温度: 5-50°C

环境温度: ≤50°C

湿度: 65% RH

最大工作压力: 0.4Mpa

Medium temperature: 5-50°C

Environmental temperature: ≤50°C

Humidity: 65% RH

Max.working pressure: 0.4Mpa

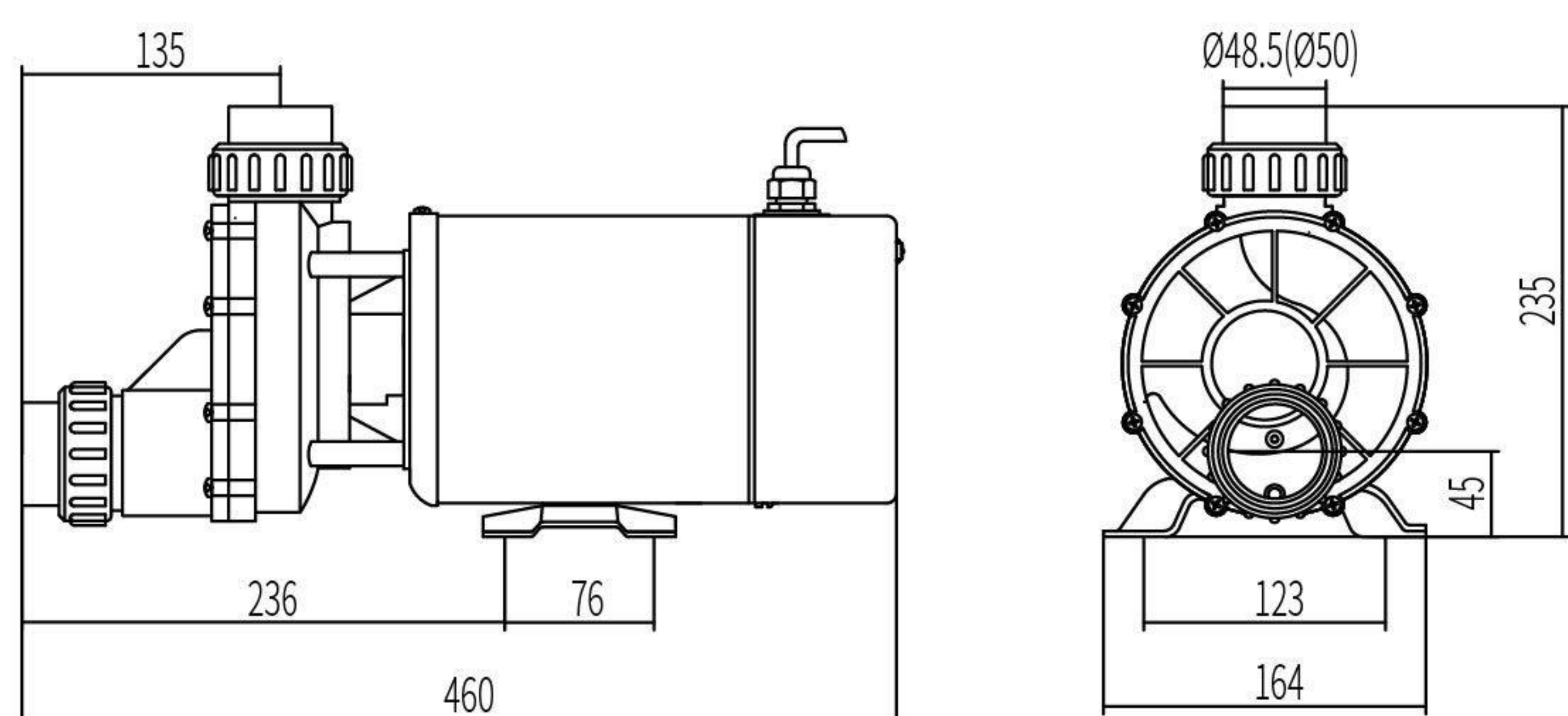

## 性能曲线 Performance Curves

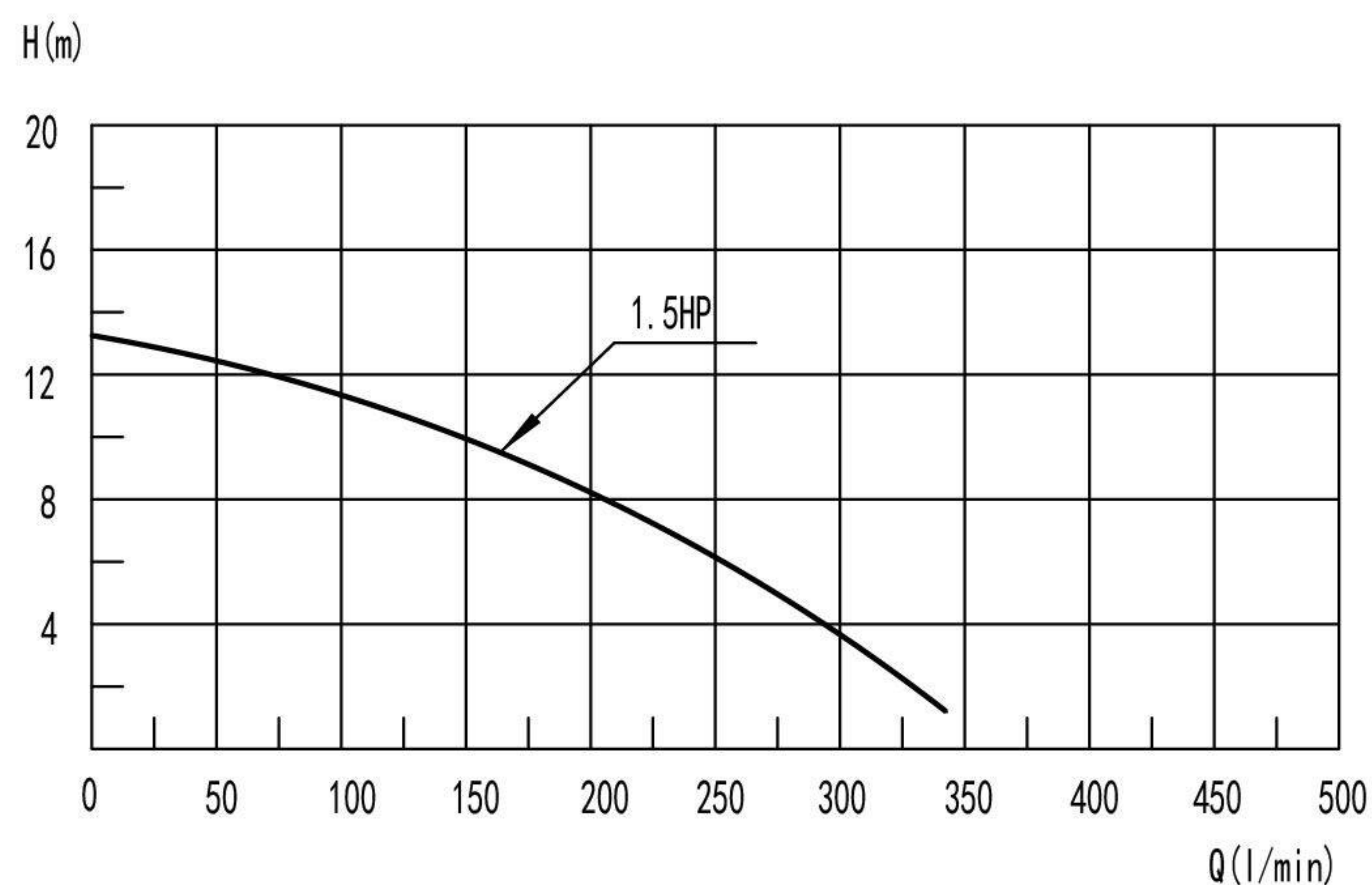

UL LISTED E351970

SF 1538624

TUV EN 60335-1:2012/A2:2019  
EN 60335-2-41:2003/A2:2010  
EN 62233:2008

CE EN 60335-1:2012/A2:2019  
EN 60335-2-41:2003/A2:2010  
EN 62233:2008

## 技术参数 Technical Parameter List

型号 Model	电压 Voltage	功率 Power		转速 Rotating Speed (r/min)	最大扬程 Maximum Lift (m)	最大流量 Maximum Flow (l/min)	绝缘等级 Insulation Class	毛重 Gross Weight (kg)	认证 Certification
		Kw	HP						
DXD-2A	230v/50Hz	1.1	1.5	2850	13.0	333	F	10.0	TUV CE
DXD-2C	230v/60Hz	1.1	1.5	3450	13.0	333	F	10.0	
DXD-1-1100	115v/60Hz	1.1	1.5	3450	13.0	333	F	10.0	UL LISTED SF

包装 (Packing): 460mm×170mm×210mm

可选配定时功能和无水保护装置 Optional function: Timer&No Water Protection